

M. ASTILL

British Nuclear Fuels plc., Risley, Warrington, England

ABSTRACT

This paper describes the remote handling equipment being designed for a plant which will reprocess irradiated fuel assemblies from Europe & Japan. The equipment will furnish facilities for production and maintenance operation in the Fuel Feed Pond, the Shear Cave, the Basket Handling Cave and the Solid Waste Export Facility.

operate continuously for long periods. The reliability of wet chemical plant is high, and faced with a basic overall plant philosophy of low cost (single line plant with no installed redundancy), the design of the mechanical plant has placed heavy emphasis on achieving maximum reliability, to minimise the liquor buffer storage between the batch-wise Head End processes and the continuous Chemical Separation processes. This will be achieved by providing simple, robust equipment backed up by comprehensive recovery and maintenance facilities. The dimensions of the materials handled, e.g. PWR fuel assemblies up to 5 metres in length weighing up to 530 kilograms and a dissolver batch size approaching 2 tonnes U, require in-cave equipment which by normal remote handling standards is very large and heavy.

1.0 INTRODUCTION

The Thermal Oxide Fuel Reprocessing Plant (THORP) will store and reprocess a wide range of uranium oxide fuel assemblies which have been irradiated in commercial power reactors. The plant is sited within the existing reprocessing complex at Sellafield, England, and it will be operated by British Nuclear Fuels plc. The Company is also carrying out the research, development, design and procurement of plant and equipment, followed by the supervision of site construction and commissioning. Fuel to be reprocessed will have been transported to Sellafield by Nuclear Transport Ltd., Pacific Nuclear Transport Ltd., (both of which are subsidiaries of BNF Plc) or the UK Home Generating Boards. Contracts have been signed with numerous reactor operators for the reprocessing of fuel amounting to several thousand tonnes. The plant will have a nominal capacity of 1,200 tonnes (U) per annum.

2.0 SCOPE

Conceptual design started in the mid '70s, whilst 1982 saw the major build-up of the project team. Work on foundations has started and orders are being placed for plant and equipment to meet a programmed plant handover in 1990. Apart from the considerable complexity of the chemical processes, THORP presents some challenging problems in the field of remote handling, to which this paper is addressed. These problems arise from the need to handle about 40 physically different types of highly radioactive fuel assemblies at a consistently high rate to meet the demands of the chemical plant, which is designed to

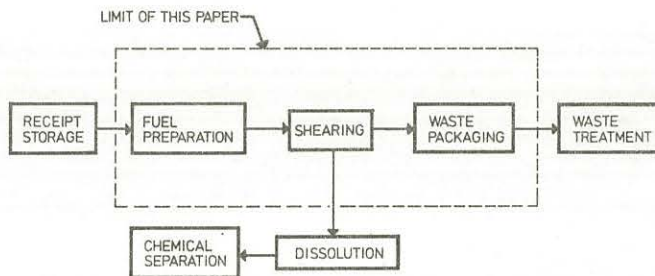

FIGURE 1 - SCOPE

A simple block diagram of the overall process is shown in Figure 1. The scope of this paper is confined to the remote handling activities in the Head End plant, between the receipt of a pond storage rack into the Feed Pond and the packaging of leached hulls and other solid wastes in the Solid Wastes Export Facility (SWEF). The paper gives a broad description of the complete remote handling system and highlights several important features.

In addition to the PWR and BWR fuel, THORP will also reprocess British Advanced Gas-cooled Reactor (AGR) fuel. These campaigns require a slightly different process; therefore, in the interests of simplicity, the handling processes described herein are the ones associated with LWR fuel only.

3.0 FEED POND

The block process diagram for the Feed Pond is shown in Figure 2 and the layout of the plant and equipment is shown in Figures 3 & 4.

3.1 PROCESS DESCRIPTION

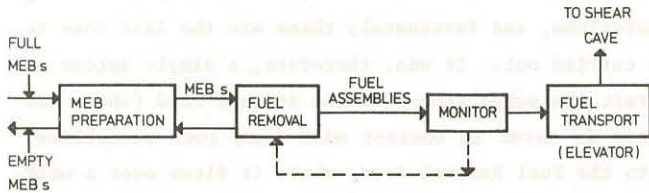

FIGURE 2 - FEED POND

LWR fuel assemblies are stored in multi-element bottles (MEBs). These MEBs are stainless steel containers featuring a bolted lid and self sealing couplings for remote connections of services for

filling, purging, venting, emptying, sampling etc. The MEBs are stored vertically in pairs in moveable racks placed in rows in the Storage Pond which is connected to the Feed Pond by the Access Channel. A rack of fuel is transported into the Feed Pond by the Access Channel Transfer Machine and is set down within the range of the Feed Pond Rack Handler. This machine moves the rack to one of a pair of MEB Preparation Stations, where service connections are made to the couplings. After venting the ullage gas to the plant vessel ventilation system, the MEB liquor is replaced by clean demineralised water. The lid is then removed and parked on a platform. All the operations at the Preparation Station are carried out by remote tools operated from a moveable platform cantilevered off the pond wall top.

The rack of fuel is then moved by the Rack Handler and taken to one of two identical Fuel Removal Stations located in a deeper part of the pond. Here the individual fuel assemblies are withdrawn from the MEB and passed through a Monitoring Station which checks the irradiation, cooling time and residual fissile content. Provided that the monitoring measurements are satisfactory, the fuel assembly is then lowered into the carrier mounted on the Elevator Bogie which will subsequently carry it up the elevator into the Shear Cave.

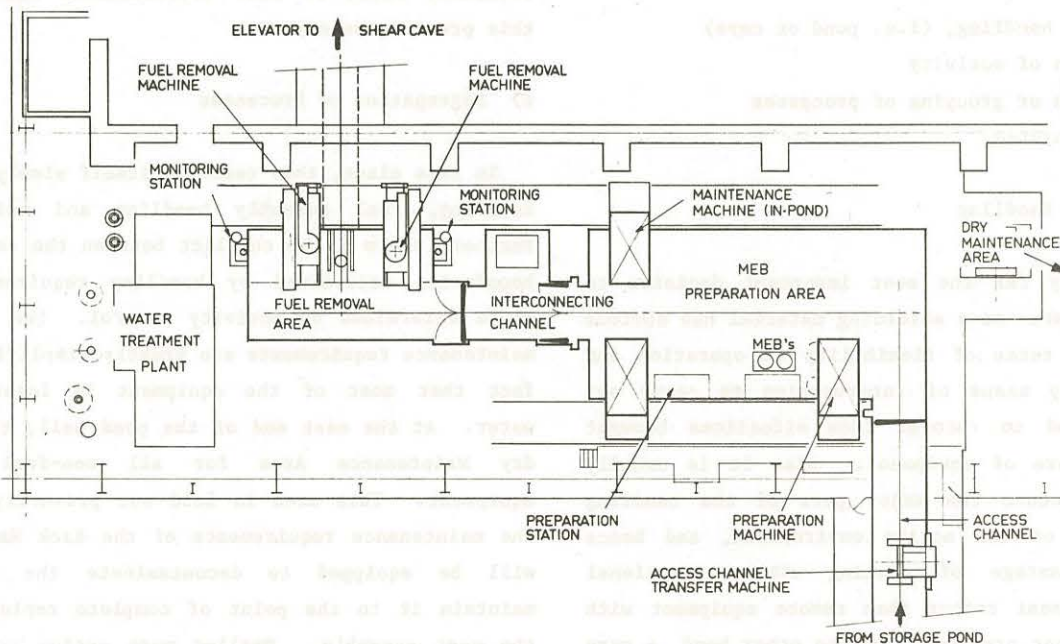

FIGURE 3 - LAYOUT FEED POND

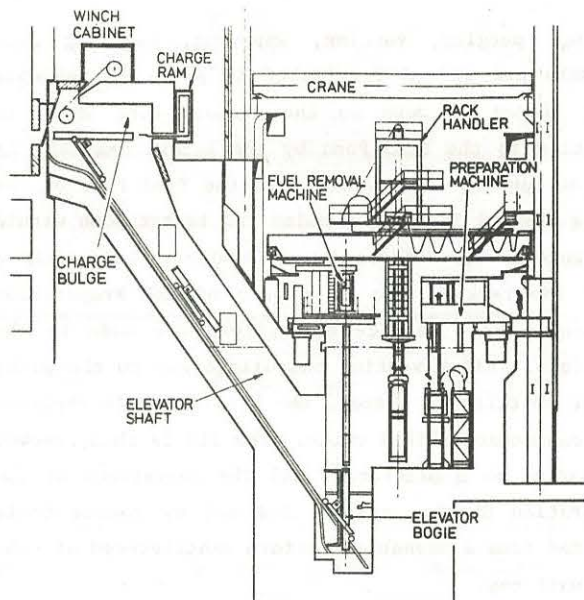

FIGURE 4 - SECTION THROUGH FEED POND

3.2 FEED POND LAYOUT

Determining the basic layout is a vital stage in the design of any remote handling system. It was particularly important in this case, owing to the way in which the large machines are closely integrated into the civil superstructure and the difficulty of making significant changes in the future. In developing a satisfactory layout the following points were considered:

- a) Wet or dry handling, (i.e. pond or cave)
- b) Segregation of activity
- c) Segregation or grouping of processes
- d) Transport system

a) Wet or Dry Handling

This was by far the most important decision to make. Using water as a shielding material has obvious advantages in terms of flexibility of operation and relatively easy means of intervention to carry out maintenance and to recover from situations brought about by failure of equipment. Also it is usually possible to locate the major part of the handling machinery out of the active environment, and hence have the advantage of dealing with conventional hands-on equipment rather than remote equipment with all its attendant problems. On the other hand, a very high degree of water containment is required, and also

some provision for water treatment to maintain the specific activity in the water within acceptable limits. Taking into account the range of different MEBs to be prepared and the even wider range of fuel elements to be handled, it was felt that a dry cave system would not provide the flexibility that was required and therefore the wet pond system was adopted.

b) Segregation of Activity

To reduce the spread of activity, it is usual to direct the flow of purge water from areas of low specific activity to areas of high specific activity, in much the same way in which one would lay out a cave in conjunction with the ventilation air flow. In this plant, the processes likely to produce pond water contamination are the fuel assembly handling operations, and fortunately these are the last ones to be carried out. It was, therefore, a simple matter to direct the purge flow from the Storage Pond (where the water is never in contact with bare fuel assemblies) into the Fuel Removal Area, where it flows over a weir into the Water Treatment Plant. A swing gate is installed in the Access Channel, its function being to increase the local velocity of the water which flows through the small gaps around its edges. A pair of similar gates are fitted between the Preparation Area and the Fuel Removal Area. The Fuel Removal Area is reduced to a minimum volume to increase the rate of change which can be effected by operating the Water Treatment Plant in full recirculation mode, should this prove necessary.

c) Segregation of Processes

In this plant, this resolved itself simply into MEB handling, fuel assembly handling and maintenance. Further, there is no conflict between the segregation boundaries determined by handling requirements and those determined by activity control. The effect of maintenance requirements are greatly simplified by the fact that most of the equipment is located above water. At the east end of the pond hall, there is a dry Maintenance Area for all non-fuel bearing equipment. This area is laid out primarily to meet the maintenance requirements of the Rack Handler and will be equipped to decontaminate the mast and maintain it to the point of complete replacement of the mast assembly. Smaller more active components, such as fuel grabs, will be transferred by shielded

containers to a centralised Decontamination and Maintenance building in THORP. Underwater maintenance facilities are restricted to a relatively small area for dealing with problems associated with MEBs.

d) Transport System

The MEBs vary in size and in detail depending on the origin of the particular fuel, and for this reason it was decided that they would remain in the racks during every movement and process operation in the Feed Pond. Thus it is not necessary to change the grapple on the Rack Handler for different fuel campaigns, as all MEB storage racks have identical lifting pintles. It was further decided that the Rack Handler would act as a transporter only and would not perform any other operations. Conversely, the other machines would not be required to move a rack once it had been set down in the station which it services. The height of the fuel racks precludes the use of the 'free pond space' concept as employed in Magnox storage ponds, where the much smaller skips of fuel rods can be carried above others. The movement of racks is therefore confined to a single East-West centre line, with the rack base only 150 mm clear of the pond floor. North-South movement is permitted only at certain points, e.g. into and out of process stations.

3.3 DESCRIPTION OF MACHINES

3.3.1 RACK HANDLER

This is the largest machine in the whole remote handling system, and its function is simply one of pickup, transport and setdown. The pickup and setdown must be performed with a high degree of precision, and the transport function must be confined to certain defined routes under a strict process control system which interfaces with other pond equipment. The accurate repeatability is obtained by use of electro-hydraulic bolts which engage in sockets on the rail support beams to hold the machine firmly in position during the pickup and setdown operations. Hoist movement is prevented unless each bolt is fully engaged and, conversely, withdrawal of the bolts is not possible unless the mast is hoisted up to transporting height.

Movements are controlled by a local computer which provides a degree of process sequence control as well as the basic safety interlocks. The computer also performs a data recording and materials management function in conjunction with the Centralised Plant Control Room. Exchange of racks between the Rack Handler and the pond-side machine is on an 'offer' and 'accept' basis which avoids any physical inter-relationships becoming necessary.

3.3.2 MEB PREPARATION MACHINE

The Preparation Machine is basically a moveable platform which overhangs the Preparation Station and is equipped with long tools for connecting hoses to the couplings on the MEB lid and other tools for unbolting the lid, removing it and parking it. Positioning the platform and operation of the tools are performed by the process operator using a combination of direct viewing through the pond water and CCTV for precise location. Once the connections have been made, the venting and flushing operations are carried out automatically. On completion of flushing, the operator returns to the platform to remove the bolts and lid. On the outward journey, the empty MEB returns to the Preparation Station to have its original lid refitted and an ullage blown in before being returned to the Storage Pond.

The Preparation Machine dominates the control of the area around the Preparation Station whilst operations are being carried out on the MEBs. When these are completed, the machine may withdraw and place the rack on 'offer' to the Rack Handler. 'Acceptance' is made by transferring control to the Rack Handler, and the Preparation Machine is automatically immobilised whilst the rack is being removed from the station.

3.3.3 FUEL REMOVAL MACHINE

It is recognised that the water velocities during MEB flushing are unlikely to remove crud which may have built up on the surface of the fuel in the reactor and which might become detached during fuel removal. This could give rise to a temporary increase in surface activity and some reduction in visibility due to suspended particulates. Both these conditions are undesirable when direct viewing by an operator positioned close to the pond surface is contemplated. It quickly became apparent that a fully remote

controlled machine was required.

The design problems are compounded by the fact that about 12 different grabs will be required to pick up the wide range of fuel assemblies located at different heights inside the MEB. The design has been concentrated on a concept whereby grabs can be readily exchanged from an underwater magazine in a safe manner whilst achieving a very high degree of integrity once attached and operating. The MEBs are randomly orientated in the racks, and therefore it is not possible to pre-programme the mast positioning. It will be necessary to position the mast over the channel in the MEB support frame and insert the grab which has the ability to gather the top of the fuel assembly onto the centerline of the channel and to lock onto it. Each grab is designed such that, once locked onto the fuel assembly, it is not possible for it to become accidentally detached. Viewing of the grab position is achieved by means of TV cameras located on the mast and on the pond walls.

The difficulties which could be experienced with the fuel grabbing operation meant that the number of these operations must be kept down to the absolute minimum. The original concept of the Fuel Removal Machine handling the fuel assembly into a monitoring machine was abandoned in favour of designing the Fuel Removal Machine to perform the dual role of fuel removal and manipulation inside a static Monitoring Station. The length of time required for the monitoring operation requires two separate machine/monitor combinations.

Following successful monitoring, the Fuel Removal

Machine will insert the fuel assembly into the Elevator Bogie Carrier for transport up into the Shear Cave. Positioning of the mast above the monitor tube and the bogie carrier will be programmed into the control system. A predetermined sequence of fuel manipulation to suit each particular fuel type will also be programmed. The design of the equipment will be supported by extensive development on a full size underwater test rig.

4.0 SHEAR CAVE

4.1 PROCESS DESCRIPTION

Each fuel assembly is raised up out of the pond and into the Charge Bulge by means of the Elevator Bogie. From there it is pushed forward onto the Feed Envelope turntable which is situated inside the Shear Cave. The turntable is rotated through 180° to position the fuel assembly in line with the Incremental Feed Ram (IFR) and the Shear Machine. This rotation also presents the fuel in the correct orientation to the Shear Machine, i.e. bottom end first. The IFR and the Shear Machine operate in unison to feed and cut the fuel pins into short lengths. These fall into the Dissolver Charge Chute which directs them into one of three dissolvers.

4.2 LAYOUT

The layout of the shear cave and its maintenance facilities is shown in Figure 5. An earlier plant at Sellafield used a shear with a blade which moved in a

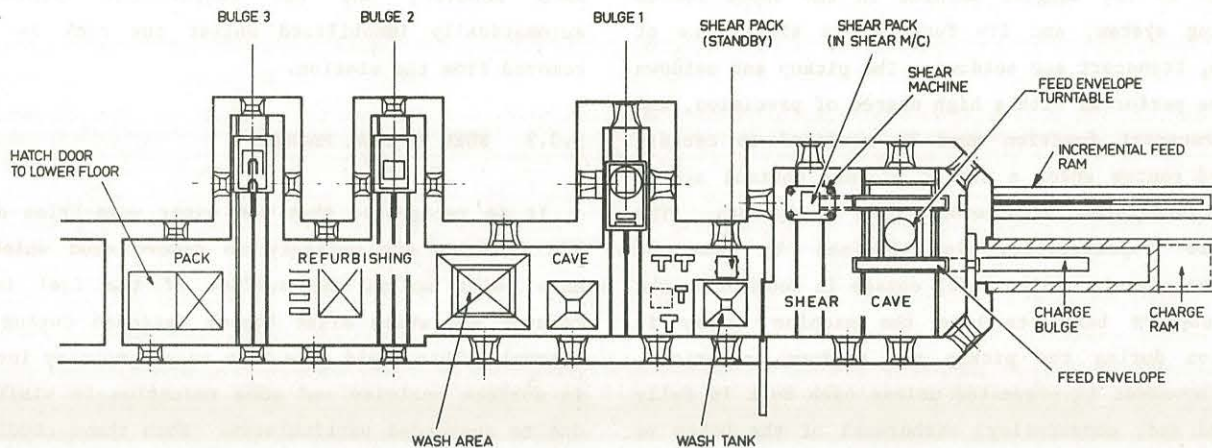

FIGURE 5 - SHEAR AND REFURBISHING CAVES

horizontal direction to shear fuel which was also fed into it horizontally. An essential feature of this shearing system was the concept of a shear 'pack', whereby all the moving parts situated in the active cave, e.g. blades, gags, bearings, slides, etc., are contained in one monolithic block which can be readily removed and replaced. Although this machine performed successfully, it was felt that a shear with a vertically moving blade would give considerable benefits in terms of debris clearance and reduction of the number of components needed to suit the range of fuel assemblies. Consequently such a shear has been designed for THORP. The 'pack' system and the horizontal fuel feed have been retained. The adoption of such a machine has a significant effect on the cave layout because of the way in which the pillars and ram shafts penetrate the cave roof and restrict the coverage of the in-cave crane and power manipulator. Figure 5 shows the shear offset from the central corridor, which also places the IFR and one of the Feed Envelopes out of the reach of the crane and manipulator. This obviously produces problems of access to the equipment, particularly for maintenance, but features have been designed into the machines to overcome these. It can be seen from Figure 5 that a large part of the total layout is occupied by comprehensive maintenance facilities. These are essential in a plant of this nature where hold-ups in production must be minimised.

4.3 DESCRIPTION OF MACHINES

There are 4 machines which constitute the remote handling system which transfers the fuel assembly from its vertical orientation underwater to its horizontal feed position in the dry cave approximately 25 metres higher in elevation. The basic concept of the system is to provide a smooth parallel tube to enclose and support the fuel assembly at all times, whilst it is being manoeuvred and subsequently fed into the shear.

4.3.1 ELEVATOR BOGIE

This serves the dual purpose of raising the fuel to the correct height and changing its orientation from vertical to horizontal (see Figure 4). The angular movement is carried out automatically in two stages as the bogie is winched up the inclined elevator. The bogie supports a pivoted Carrier which undergoes

partial rotation during the initial few metres of travel to bring it parallel with the centreline of the elevator tunnel. The remainder of the rotation occurs during the last few metres of travel as the bogie enters the Charge Bulge. Both stages of rotation are produced by the action of cam followers acting on tracks in the elevator tunnel. The Elevator Bogie and Carrier are very simple. Complete wheel units and pivot units are designed in a modular fashion for easy replacement in the Feed Pond.

4.3.2 CHARGE BULGE

This houses equipment to support the Carrier in its upper position and to charge the fuel assembly into the Shear Cave. As the Elevator Bogie comes into the bulge, it over-travels slightly to allow a pair of support beams to be slid into position. The bogie is then lowered until the Carrier is resting on the beams and is correctly aligned with the Feed Envelope. The bottom end of the Carrier comprises a ram head which automatically engages with the Charge Ram as the Carrier completes its rotation to the horizontal position. Once the connections have been made, the Charge Ram pushes the fuel assembly, top end first, into the Feed Envelope. No maintenance operations are required inside the Charge Bulge as all the equipment prime movers are mounted outside. The Charge Ram is a proprietary pusher chain which emerges from and retracts into a shielded box sealed on the rear outside face of the bulge.

4.3.3 FEED ENVELOPE TURNTABLE

Having entered the Shear Cave, the fuel assembly needs to be moved from the cave charging centreline to the shear feed centreline and to be turned round, so that its bottom end fitting enters the Shear Machine first. Both these operations are carried out simultaneously by rotating the turntable which has the Feed Envelopes mounted off centre. Two envelopes are provided to reduce the time cycle, and these are mounted on slides to allow them to be moved horizontally out of the arc of rotation to engage in either the bogie Carrier or the Shear Pack. All the drives to the turntable are located outside the cave, and the in-cave moving parts are arranged in modules for easy removal and replacement. Maintenance of an envelope is carried out when it is under the coverage

of the in-cave crane and power manipulator. The turntable bearing is massive, but, in the unlikely event of it requiring maintenance, the complete turntable bedplate can be slid sideways on its support beams to bring it within reach of the remote maintenance tools. The turntable is fitted with screw jacks to support it whilst the bearing module is simply lifted out.

4.3.4 INCREMENTAL FEED RAM

The duty of the IFR is to position the fuel assembly to enable cuts to be made at the required points along its length. The first cut removes the bottom end fitting, and subsequent cuts are made at regular intervals until the plenum section is reached. Depending upon the fuel type, this is either cut from the top end fitting or both are pushed through together. The fuel assembly is pushed by the IFR shaft which passes through a sealing plug in the cave wall. The ram shaft has a head on the in-cave end which is a close fit in the Feed Envelope, whilst the out-cave end is connected to a traversing mechanism. The complete out-cell unit is contained in a double sealed cabinet, the outer cabinet being removed to gain access to the traversing mechanism which drives the ram shaft via a sliding 'zipper' type seal in the inner cabinet. The traversing mechanism drive is programmable to suit the various fuel assemblies.

4.3.5 SHEAR MACHINE

The shear machine is shown in Figure 6, together with the shear pack removal bogie. The design of this machine has been based on experience gained on an earlier reprocessing plant plus extensive research and development using a 4,000 kN inactive replica shear, fitted with a data collection system. Fuel element shears present difficult remote handling problems due to their size, high wear rate and heavy contamination. In a high capacity production plant such as THORP, it is essential that the shear machine and its maintenance facilities are designed from the beginning as one fully integrated system. As stated earlier, the shear pack concept, which proved so successful before, has been adopted for THORP. Under this concept, no maintenance is carried out on the Shear Machine in its operating position in the Shear

Cave other than removal and replacement of the Shear Pack. The vertical orientation of the shear requires the use of a sideways transporting mechanism to effect this exchange. This can be seen in Figure 6. The bogie has a pair of tapered platforms which set down and pick up the pack automatically over a small length of bogie travel. The movement of the pack is normal to the face of the bottom shear platen, therefore no scraping takes place.

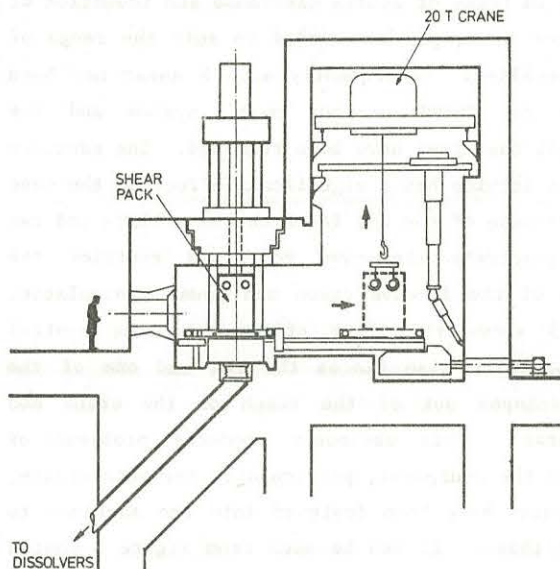

FIGURE 6 - SHEAR MACHINE

A worn shear pack will be taken into the Pack Refurbishing Cave which is adjacent to the Shear Cave. This area is provided solely for the purpose of dismantling a pack, removing the worn components, and reassembling the pack using new ones. The area is furnished with dedicated, robust equipment housed in 3 bulges off a transport corridor. All foreseeable failure modes have been carefully studied and a maintenance procedure worked out for each. Tools, lifting adaptors, stillages, gauges, etc., have been designed for each procedure, and whilst there has inevitably been some rationalisation, the accent on simplicity has been maintained by adopting a preference for single purpose units rather than for more versatile but potentially less reliable ones.

Bulge No.1 is where the primary modules are removed from the pack, and this is done by simply lifting the moving blade carrier, gag module and anvil modules straight out of their locations within the pack shell. The ability to do this so easily is another advantage of a vertical shear layout. The modules are

then moved to either Bulge No.2 or No.3 where the more precise tasks of removing individual components are carried out. It can be seen from Figure 7 that the equipment in these bulges consists basically of a moving bench, a wall turret and a roof turret. The bench is fitted with all the necessary holding and manipulating fixtures to suit the particular module being serviced. General viewing is through solid glass windows with CCTV for closer observation of specific operations. Three Shear Packs will be provided, the principle being one in use, one completely refurbished on standby and the third undergoing refurbishment. The design of the pack and its refurbishing equipment has been supported by development work using a full size mock-up of the pack and two of the bulges.

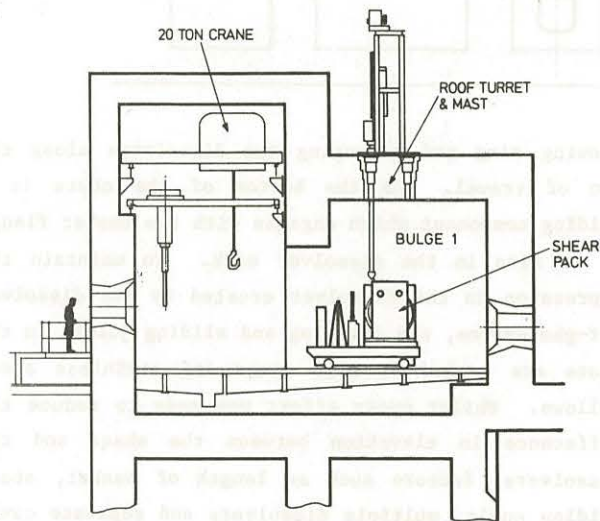

FIGURE 7 - PACK REFRUBISHING CAVE

5.0 DISSOLVER BASKET HANDLING CAVE

The block diagram for the fuel dissolution process and the solids waste handling is shown in Figure 8, and a sectional elevation of the cave is shown in Figure 9.

5.1 PROCESS DESCRIPTION

Short lengths of sheared fuel pins fall down the Dissolver Charge Chute, together with all other materials which make up the complete fuel assembly. This material is caught in a fine-meshed, stainless steel basket hanging inside the dissolver which contains nitric acid at high temperature. When the

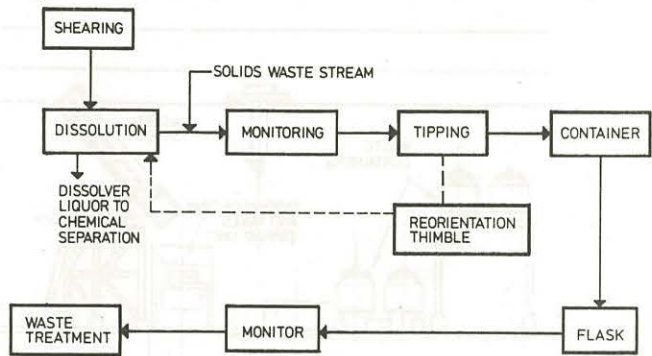

FIGURE 8 - DISSOLUTION AND SOLIDS WASTE HANDLING

charging process is complete, the chute is disconnected, the dissolver neck closed and dissolution of the fuel continues. Meanwhile, the chute is moved to another dissolver. When the dissolution process is completed, the basket is lifted out of the dissolver by the in-cave crane which carries it to the Hull Monitoring Station. Here the basket is manipulated by the Monitoring Machine past instruments which measure the amount of undissolved fuel which might be present.

After satisfactory monitoring, the basket is moved to the Basket Tipper, where the insoluble stainless steel and zircalloy waste is tipped out onto the Discharge Tray. From here the waste is poured into the Diverter Bogie, which directs it to either a waste container for disposal or an empty dissolver basket for reorientation and further dissolution. The waste container is filled with water and a lid is fitted prior to transfer to the Solid Waste Export Facility (SWEF). Baskets and containers are transported about the cave by cranes.

5.2 LAYOUT

The machinery is laid out in line with the sequence of process stages, minimising travel between machines as materials handled move progressively along the cave from the dissolvers to the waste transfer tube. Early assessment of time cycles identified the need for two cranes, one to handle baskets and the other to handle containers. Although the cranes are identical and share the same rails, the grabs are different, and therefore basket handling operations are restricted to the South side of the Basket Tipper and the container handling to the North. Buffer stores for baskets and containers provide some flexibility between the dissolvers, in-cave machines and SWEF.

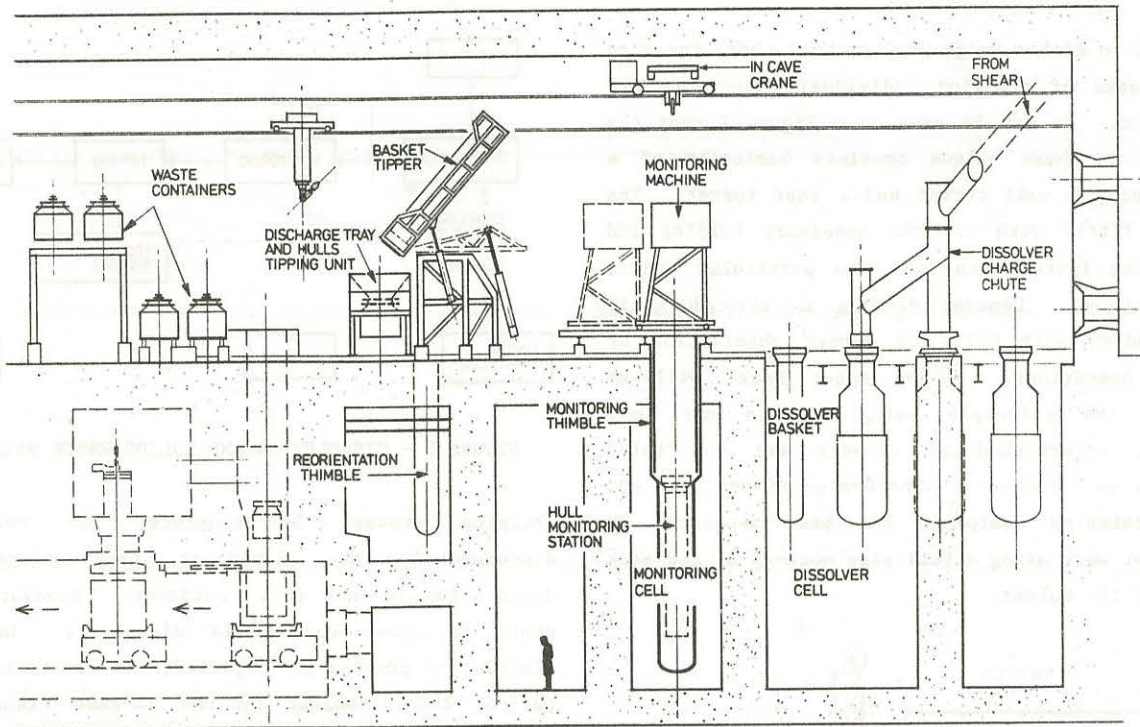

FIGURE 9 - DISSOLVER BASKET HANDLING CAVE

5.3 DESCRIPTION OF MACHINES

Studies examining the plant capacity, dissolution cycle, number of dissolvers and dissolver batch size resulted in the need for a dissolver basket approximately 800 mm dia. x 5,500 mm long which weighs approximately 2.5 tonnes when empty. To ease operational control, the waste container was sized to accept the waste from one dissolver batch and has a gross volume of approximately 1,300 litres. These two items are handled, on a constant production basis, several times per day, and consequently the equipment is on a considerably larger scale than that which is usually found in remote caves. The major production machines are the Dissolver Charge Chute, the Monitoring Machine, the Hulls Tipping Unit and the in-cave cranes. Owing to the presence of nitric acid fumes, all machines must have a high degree of corrosion resistance.

5.3.1 DISSOLVER CHARGE CHUTE

The requirement to serve any one of three dissolvers introduced a complication such that the simple chute has also to perform as a distributor. This is achieved by pivoting the lower portion on a

slewing ring and arranging the dissolvers along the arc of travel. At the bottom of the chute is a sliding component which engages with the basket flange as it sits in the dissolver neck. To maintain the depression in the dissolver created by the dissolver off-gas system, the rotating and sliding joints in the chute are sealed by slip rings and stainless steel bellows. Whilst every effort was made to reduce the difference in elevation between the shear and the dissolvers, factors such as length of basket, steep sliding angle, multiple dissolvers and separate caves for shearing and dissolving resulted in a vertical dimension of 13 m from the shear blade to the dissolver neck. As the fuel assembly end fittings weigh up to 25 kg, impact damage was a prime consideration in the chute design. Computerised stress analysis and drop tests have confirmed the suitability of the engineering features in the machine. These features include removable shock absorbing sleeves fitted inside the chute at changes in direction where maximum impact is expected.

5.3.2 MONITORING MACHINE

The basket of leached hulls must be monitored for undissolved fuel before any other operation is carried out. This requires the basket to be moved vertically and rotated within the sensing range of the monitoring instruments. The instruments are mounted outside an

open necked Monitoring Thimble, which is sealed into the cave floor and hangs down into a Monitoring Cell below. The basket is lowered into the thimble by the crane onto a temporary support collar, the Monitoring Machine being moved aside whilst this takes place. To complete the exchange, the machine moves over to the centreline of the thimble and picks up the basket in its own grab. The machine hoisting and rotating drives are programmed to manipulate the basket in the correct sequence.

5.3.3 HULLS TIPPING UNIT

This is a group of interacting machines comprising the Basket Tipper, the Discharge Tray and the Diverter Bogie, which together serve the purpose of transferring the solid waste from the Dissolver Basket to the Waste Container or, unusually, to another Dissolver Basket hanging in the Reorientation Thimble.

The pieces of waste vary greatly in size, shape and weight, from the large end fittings down to small particles of insoluble metal fines. Past experience has shown how unpredictable the behaviour of such a mass of metal can be when poured. To minimise the spread of trajectories taken by the contents, the tipping action takes place in two stages. First the basket is pivoted about a point roughly midway along its length until it is horizontal, then the pivot is transferred to a point near to the basket neck for the remaining 50° of tip. Both movements are powered by pairs of electro-hydraulic rams. The basket is held in the tipping frame by an automatic pendulum lock.

As a further measure to reduce the spillage of waste, an intermediate step was introduced between the basket and the container. This is the Discharge Tray which is a large open tray with high sides and a spout through which the waste is poured as the tray itself is tipped. Tipping from the open tray can be done in a much more controlled manner than from the basket, where viewing and assistance by manipulators is not possible. Furthermore, the waste lying on the tray gives the first opportunity for the sheared product to be directly viewed, and this would give valuable information on the shear/IFR performance.

Under normal operation, the Diverter Bogie will carry a Waste Container sideways into a position underneath the spout of the tray to receive a charge

of waste. However, as mentioned earlier, there is a possibility for a small amount of fuel to remain undissolved due to unfavourable orientations of closed ends of pins in the basket. Thus the Diverter Bogie also carries an offset-hopper which can be positioned under the spout to direct the waste into an empty dissolver basket which has previously been fitted into the Re-orientation Thimble. This thimble is merely an open topped vessel which is sealed into the cave floor in a similar manner to the Monitoring Thimble. The re-orientated waste can then go through a further leaching operation.

After filling, Waste Containers are topped up with water to cover the waste material and to avoid any chance of fire. A lid is fitted and the container placed in the buffer store awaiting transfer to the Solid Waste Export Facility.

5.3.4 IN-CAVE CRANE

In-cave cranes have proved themselves to be more reliable than bridge mounted power manipulators, probably as a result of being relatively simple. Nevertheless, it is usual for them to be used as maintenance tools with perhaps some limited production duties. The principal reason for this is that failure of an in-cave crane in certain circumstances may require very difficult and expensive recovery operations to be undertaken before production can be resumed.

For the handling of dissolver baskets and waste containers between the various machines and stores in this cave, there was no other practical alternative to using the crane as a production machine. Furthermore, the utilisation is such that two cranes are necessary, each having a utilisation a little over 50% at maximum plant throughput. Clearly the need is for high reliability backed up with pre-planned recovery procedures and rapid maintenance. The crane components will also have to withstand nitric fumes, as the basket is lifted and held suspended above the open dissolver and allowed to drain. The crane system has the following features:

- a) All stainless steel with 'clean lines'.
- b) No electrical components on the crab. Power for hoist and cross travel transmitted by shafts from a

sealed box on one end of the bridge.

c) 3 axis position control system to restrict the crane to essential set-down points and to designated transport routes between each.

d) Electro-magnetic clutches on traversing drives, with means of manoeuvring along transport routes to the nearest set-down point using external means.

e) Through-roof emergency hoist drives at all set-down points.

f) Two identical cranes on the same rails, each being able to take over the other's duties at a reduced plant throughput.

g) Complete modularisation of the crane sub-assemblies, integrated into the design of

comprehensive decontamination and maintenance facilities at the North end of the cave.

6.0 SOLID WASTE EXPORT FACILITY

A sectional elevation of SWEF is shown in Figure 10. Waste containers are sealed in the Basket Handling Cave and cleaned externally to remove gross contamination, before being lowered down the transfer tube into a flask which is sealed against the bottom end of the tube by a jacking mechanism on the bogie. The lid of the flask is replaced and the cell doors opened to allow the flask to be taken through a series of decontamination and monitoring stages before it is exported from THORP to a separate plant elsewhere on the site. The equipment in SWEF has no particular significance from a remote handling aspect and it will not be described further.

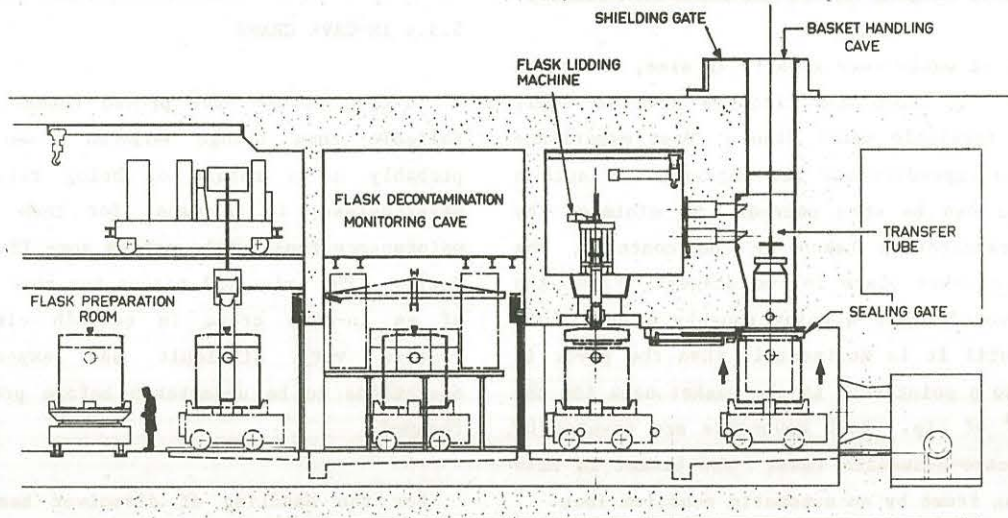

FIGURE 10 - SOLID WASTE EXPORT FACILITY