

ANALYSIS OF THE FAST-NEUTRON SPECTRUM INSIDE THE EXPERIMENTAL CAVITY OF THE NRU Mk4 FN ROD

T. C. Leung

Atomic Energy of Canada Limited
Reactor and Radiation Physics Branch
Chalk River Laboratories
Chalk River, Ontario KOJ 1J0

Abstract

The fast-neutron (FN) rods in the NRU reactor provide a facility to study the effects of irradiation on CANDU* reactor materials. The Mark 4 (Mk4) FN rods use natural uranium and supply fast-neutrons for experiments on irradiation creep and growth, and corrosion, for pressure- and calandria-tube materials. The neutron fluxes above 1 MeV are up to 2.7×10^{17} n.m⁻².s⁻¹.

This paper describes a calculation of the fast-neutron spectrum inside the NRU Mk4 FN rod cavity. The calculation was performed using the WIMS-AECL code, which is a multi-group transport code with two-dimensional capabilities using the collision-probability method. Results for the fast-neutron spectrum above 1 MeV are presented in nine groups. The analysis confirms that the spectrum in the fast-neutron irradiation facility in NRU is representative of the actual irradiation spectrum for fast-neutron damage in a CANDU reactor.

The effects of changes in specimen holder size, temperature, coolant density and fuel burnup on the fast-neutron spectrum are also presented.

1. INTRODUCTION

A good understanding of the effect of irradiation on materials is essential for predicting and preventing the failure of structural components in operating nuclear reactors [1]. At Chalk River Laboratories, particular research emphasis has been placed on fast-neutron radiation damage studies and our ability to predict in-reactor deformation and metallurgical behaviour changes when reactor materials are subject to high neutron fluxes and fluences [2,3,4]. The materials of specific interest are zirconium and its alloys, which are used in the pressure tubes and calandria tubes of CANDU reactors.

The fast-neutron (FN) rods in the NRU reactor provide a facility to study the effects of irradiation on CANDU reactor materials. Current in-reactor test programs include experiments on irradiation creep and growth, and on corrosion. All these irradiation experiments require accurate determination of neutron fluences for the interpretation of experimental results.

With increasing requirements for quantitative evaluation of fast fluxes to cross-correlate results of different test reactors and assess their applicability to power reactors, more accurate assessments of fast fluxes in our irradiation facilities are required. Accurate determination of the neutron fluences > 1 MeV requires an effective cross-section of the Fe⁵⁴ (n,p) Mn⁵⁴ reaction of the iron-wire flux monitors, that is based on a neutron spectrum for the actual configuration of the facilities in NRU. An appropriate effective cross-section would be obtained by averaging over the specific neutron spectrum at the irradiation location. It is therefore necessary to have a detailed analysis of the spectrum in which material specimens are irradiated, and to determine the factors that

*CANDU: CANada Deuterium Uranium; registered trademark

may induce spectrum changes. This paper describes the spectral analysis work for the NRU Mark 4 (Mk4) FN rods. Similar work is currently being carried out to determine more accurately the spectra of other high-flux reactors at the specific irradiation locations of the material specimens.

2. THE NRU Mk4 FN ROD

The NRU reactor at Chalk River Laboratories is heavy-water cooled and moderated, with on-line refuelling capability. It is licensed to operate at a maximum power of 135 MW, with a peak thermal flux of approximately $4.0 \times 10^{18} \text{ n.m}^{-2}.\text{s}^{-1}$ [5].

Two types of FN rods are used in the NRU reactor: Mk4 and Mk7. The former uses natural uranium and provides fast-neutron fluxes ($> 1 \text{ MeV}$) of $2.7 \times 10^{17} \text{ n. m}^{-2}.\text{s}^{-1}$. It occupies six or seven sites in the reactor and has been operating successfully for many years. The latter uses enriched uranium and is in the prototype stage, providing fast-neutron fluxes ($> 1 \text{ MeV}$) of $5.5 \times 10^{17} \text{ n.m}^{-2}.\text{s}^{-1}$.

Figure 1 shows a Mk4 FN rod assembly, which has an overall length of 7.825 metres. It consists of an outer flow tube and an inner flow tube, with its bottom end closed to form a cavity. Experimental inserts enclosed in pressure tubes are placed inside the central cavity. At the top of each experimental insert is an integral shielding plug, with tubes for the passage of service leads and water piping for cooling.

A Mk4 rod contains approximately 32 kg of natural uranium, in the form of sintered UO_2 fuel arranged in three 15-element bundles, each approximately 49.5 cm long. The fuel bundles are located in the annulus formed by the outer and inner flow tubes, and the fuel is cooled by heavy water. The maximum operating power for a Mk4 FN rod is 1.65 MW. The coolant flow over the fuel is maintained at 12.5 kg/s, with an inlet temperature of 40°C .

3. METHOD OF ANALYSIS

Fast-neutron fluxes were calculated using the WIMS-AECL [6] code, with its associated ENDF/B-V derived data base [7]. WIMS-AECL is a multi-group transport code with two-dimensional capabilities using the 'Pij' collision-probability method. The main transport calculations were performed using 34 energy groups, with a nine-group subdivision above 1 MeV.

The present study used a super-cell model, which included a representation of neighbouring assemblies in an attempt to provide the correct driving spectrum for the FN rod. Neighbouring driver fuel rods were modelled as one fuel ring located at a radius of 23.0 cm from the centre of the cell. The fuel loading in this ring was about 3 g/cm of U-235. A boron-10 ring was added outside the fuel ring, to keep the super-cell k-infinity close to 1.0, and to set the global flux shape.

The experimental insert was modelled as four annuli: the first for the centre flow tube, the second for the inner support tube, the third for the specimen holder and specimens, and the fourth for the enclosing pressure tube.

Details of the NRU Mk4 FN rod and a typical experimental insert, as modelled for the WIMS-AECL calculations, are shown in Figures 2 and 3, respectively.

4. NEUTRON SPECTRUM IN THE EXPERIMENTAL CAVITY

Table 1 lists the calculated neutron-flux spectrum for energies above 0.1 MeV in the experimental cavity of the NRU Mk4 FN rod. The neutron-flux is normalized to a linear rod power of 1.05 MW/m, or 1.65 MW total rod power. In Table 1 and Figure 4, the calculated neutron-flux spectrum is compared with the spectra at

the pressure tube and calandria tube of a fuel channel containing 37-element CANDU fuel bundles [8]. For each spectrum, the sum of neutron flux of all energy groups was normalized to be 100%. At energies above 1 MeV, the calculated spectrum in the experimental cavity of the FN rod is observed to lie between the spectra of the pressure tube and the calandria tube.

For the NRU Mk4 FN rod, the percentage of neutron flux above 1 MeV is 6.5%, and for the pressure tube and calandria tube it is 7.4 and 5.6%, respectively. The reasonably good agreement between these neutron spectra confirms that the spectrum in the NRU fast-neutron irradiation facility is representative of the actual irradiation spectrum in a CANDU reactor.

5. FLUX MEASUREMENT

Threshold-activation materials are useful spectral indicators for flux measurements, because they are only sensitive to neutrons above their threshold energy. In NRU, iron wires are used as flux monitors for the Mk4 FN rods. The reaction $\text{Fe}^{54}(n,p)\text{Mn}^{54}$ has an effective threshold at approximately 1.05 MeV. The measured activity of Mn^{54} , with a 312.5-day half-life, is used to determine the fast-neutron flux above 1 MeV.

The measured activity of Mn^{54} was first corrected for counter efficiency to obtain the absolute activity. The absolute activity, A, is related to the fast-neutron flux ϕ (> 1 MeV) by:

$$A = N\sigma_{FE} \phi (1 - \exp(-\lambda t_1)) \exp(-\lambda t_2) \quad \dots(1)$$

where N is the number of iron atoms per unit mass of wire,
 t_1 is the irradiation time in the reactor at an assumed constant flux, ϕ ,
 t_2 is the counting delay time after irradiation, and
 λ is the decay constant of Mn^{54} .

σ_{FE} is the effective iron cross-section, which can be written as

$$\sigma_{FE} = \sum \sigma_i \phi_i / \sum \phi_i, \text{ summed over all energy groups above 1 MeV.} \quad \dots(2)$$

σ_i is the average iron cross-section in energy group i, and ϕ_i is the flux in that group. The appropriate effective cross-section is obtained by averaging over the specific spectrum at the irradiation location. For NRU, it is the WIMS-calculated spectrum in the experimental cavity of the Mk4 FN rod.

The present WIMS group structure is limited to 10 MeV. The $\text{Fe}^{54}(n,p)\text{Mn}^{54}$ reaction has a significant cross-section at energies greater than 10 MeV, and it is necessary to generate group-integrated fluxes up to 20 MeV. If the first nine-group average fluxes generated by WIMS (1.05 to 10 MeV) are fitted, the fluxes can be described by a fission spectrum of the form:

$$\phi(E) = \phi_0 E^{1/2} \exp(-E/T) \quad \dots(3)$$

where ϕ_0 and T are fitted parameters.

This expression was used to generate group-integrated fluxes for the energy region from 10 to 20 MeV. Table 2 shows how the effective iron cross-section is calculated for energies from 1.05 to 20 MeV. The iron cross-section data was taken from Reference [9]. Since the contribution for energy groups above 10 MeV is only approximately 0.5% of the total effective cross-section, any error introduced in the flux-extrapolation procedure will not significantly affect the final result of the iron cross-section.

From Table 2, the effective iron cross-section in the NRU Mk4 FN Rod is 106.6 ± 3.0 mb, compared to

the previously used value of 106.0 mb, obtained by averaging over a spectrum taken near the pressure tube around a carrier bundle [9] similar to a 37-element CANDU fuel-bundle. The two values are similar because the NRU FN rod spectrum matches the pressure-tube spectrum of a CANDU fuel bundle quite closely.

Current work is being undertaken to determine more accurately the spectra at the specimen irradiation locations of other high-flux reactors. Subsequently, the appropriate effective iron cross-sections, and the correct neutron fluences for the irradiated specimens in those facilities, will have to be re-evaluated. Until that is done, experimental data on irradiation growth specimens from NRU and other high-flux reactors cannot be properly correlated or compared.

6. EFFECTS ON THE FAST-FLUX SPECTRUM

Fast fluxes in a Mk4 FN rod are affected by changes in insert geometry, rod burnup, and coolant temperature and density. This section describes the impact on the fast-neutron fluxes, and the effective iron cross-section, of a variety of changes in conditions.

6.1 Impact of the Insert Geometry

The insert geometry has a significant effect on the flux spectrum of the experimental cavity. If the insert contains more moderating material, the fast-flux component will diminish. In Table 3 it is shown that the fast-flux component of the spectrum can be reduced to 6.37% (Case 2) or increased to 6.69% (Case 3), when the specimen holder sizes are reduced or increased, respectively. In Case 2, as the smaller specimen holder occupies a smaller volume in the experimental cavity, more water is present, and consequently the fast flux is reduced. In Case 3, less water is present, so the fast-flux component of the spectrum increases.

Results of various changes in specimen holder position are listed in Table 3, Cases 4 and 5. The further the specimen holder moves away from the centre, but closer to the 15-element fuel bundle of the FN rod, the higher are the fast fluxes.

6.2 Coolant Density Effects

The change of coolant density within the experimental cavity of the FN rod also has a noticeable effect on the fast fluxes. If the water density is reduced, the number of atoms available for slowing down fast-neutrons is also reduced. This will increase the percentage of the fast-neutron flux component. The results at two coolant densities are listed in Table 3, Cases 6 and 7.

6.3 Temperature Effects

If the temperature of the coolant increases, the fast flux is expected to increase, because the high temperature reduces the coolant density and also the amount of moderating material in the experimental cavity. The temperature effect is listed in Table 3, Case 8.

6.4 Burnup Effects

As a FN rod burns up, the neutron production per unit fission power and the fission spectrum change, due to the depletion of U-235 and the buildup of Pu-239. Table 3 lists flux data for the fuel-burnup effect in Case 9. The fast-neutron component of the spectrum is shown to increase slightly (+0.13%) at a burnup of ~5000 MWD/TE.

7. CONCLUSIONS

The main conclusions of this study are:

1. The calculated fast flux spectrum (> 1 MeV) within the FN rod experimental cavity was found to match the actual irradiation spectrum for fast-neutron damage in a CANDU reactor.
2. The effective iron cross-section, averaged over the fast-neutron spectrum at the irradiation location in an NRU FN rod, was determined to be 106.6 ± 3.0 mb.
3. Increasing the specimen holder size or moving the specimen holder closer to the fuel bundle of the FN rod can cause an increase in the fast-neutron component of the spectrum.
4. Reduction in coolant density, or increase in coolant temperature, or increase in fuel burnup, can also cause an increase in the fast-neutron component of the spectrum in the experimental cavity.

ACKNOWLEDGMENTS

The work described in this paper was funded by the CANDU Owners Group, Program 6516, Working Party 32.

The author would like to thank N. Christodoulou and M. Miller for initiating this study, and M.D. Atfield for supervising the analysis.

REFERENCES

- [1] J.T. Dunn, "CANDU 600 Fuel Channels Assessment of Pressure Tube Failure at Pickering 'A'", AECL report, TDAI-362, 1984 June.
- [2] V. Fidleris, "The Irradiation Creep and Growth Phenomena", Journal of Nuclear Materials, 159 pp 22-42, 1988.
- [3] A.R. Causey, F.J. Butcher and S.A. Donohue, "Measurement of Irradiation Creep of Zirconium Alloys using Stress Relaxation", Journal of Nuclear Materials, 159 pp 101-113, 1988.
- [4] N. Christodoulou, M.A. Miller and A.R. Causey, Unpublished Internal Report, 1994.
- [5] D.T. Nishimura, "Summary of Loops in Chalk River NRX and NRU Reactors", AECL report, AECL-6980, 1980 December.
- [6] J.V. Donnelly, "WIMS-AECL, A User's Manual for the Chalk River Version of WIMS", AECL report, AECL-8955, 1986 January.
- [7] G.L. Festarini, Unpublished Internal Report, 1985 April.
- [8] R.E. Donders, Unpublished Internal Report, 1988 March.
- [9] M.B. Zeller, Unpublished Internal Report, 1991 January.

Table 1
Comparison of Neutron Spectra Between the NRU Mk4 FN Rod, and the Pressure and Calandria Tube of a CANDU Fuel Channel

G R O U P	ENERGY WIDTH MeV	NRU Mk4 FN ROD FLUX	NRU Mk4 FN ROD FLUX	PT FLUX of CANDU FUEL CHANNEL	CT FLUX of CANDU FUEL CHANNEL
		$\times 10^{16} \text{ n.m}^{-2}.\text{s}^{-1}$	%	%	%
1	7.79-10.0	0.177	0.055	0.060	0.045
2	6.07-7.79	0.500	0.157	0.175	0.132
3	4.72-6.07	1.115	0.350	0.392	0.298
4	3.68-4.72	1.823	0.573	0.647	0.488
5	2.87-3.68	2.729	0.858	0.973	0.741
6	2.23-2.87	3.590	1.129	1.306	0.995
7	1.74-2.23	3.482	1.095	1.236	0.935
8	1.35-1.74	3.695	1.162	1.302	0.998
9	1.05-1.35	3.565	1.121	1.265	0.979
Sub-total		20.676	6.500	7.356	5.611
10	0.82-1.05	3.456	1.087	1.246	0.991
11	0.64-0.82	3.762	1.183	1.509	1.207
12	0.50-0.64	3.190	1.003	1.321	1.065
13	0.39-0.50	2.377	0.748	0.914	0.767
14	0.30-0.39	2.787	0.876	1.232	1.062
15	0.24-0.30	2.548	0.801	1.213	1.062
16	0.18-0.24	2.301	0.723	1.151	1.021
17	0.14-0.18	2.062	0.648	1.088	0.976
18	0.11-0.14	1.972	0.620	1.043	0.954
Sub-total		24.455	7.689	10.717	9.105
19	0.625×10^{-6} - 0.11	63.019	19.811	25.171	25.425
Th.	Below 0.625×10^{-6}	209.940	66.000	56.756	59.859
Total		318.090	100.000	100.000	100.000

Table 2
Calculation of the Effective Iron Cross-Section For the Experimental
Cavity of the NRU Mk4 FN Rod

E_{lower} (MeV)	E_{upper} (MeV)	σ_{FE} (mb)	Flux-weighting factor	Weighted σ_{FE} (mb)
1.05	1.35	7.54×10^{-1}	1.72×10^{-1}	1.30×10^{-1}
1.35	1.74	3.27×10^0	1.78×10^{-1}	5.82×10^{-1}
1.74	2.23	2.12×10^1	1.68×10^{-1}	3.56×10^0
2.23	2.87	7.56×10^1	1.73×10^{-1}	1.31×10^1
2.87	3.68	1.90×10^2	1.32×10^{-1}	2.51×10^1
3.68	4.72	2.93×10^2	8.80×10^{-2}	2.58×10^1
4.72	6.07	4.13×10^2	5.38×10^{-2}	2.22×10^1
6.07	7.79	4.69×10^2	2.41×10^{-2}	1.13×10^1
7.79	10.00	4.77×10^2	8.54×10^{-3}	4.07×10^0
10.00	11.91	4.69×10^2	1.30×10^{-3}	6.10×10^{-1}
11.91	13.50	4.20×10^2	2.86×10^{-4}	1.20×10^{-1}
13.50	14.92	3.47×10^2	8.11×10^{-5}	2.81×10^{-2}
14.92	16.91	2.49×10^2	3.08×10^{-5}	7.67×10^{-3}
16.91	20.00	1.55×10^2	6.74×10^{-6}	1.05×10^{-3}
Total			1.000	106.6 mb

The uncertainty in σ_{FE} is estimated to be ± 3 mb.

Table 3
Summary of Effect on Neutron Spectrum

Case	Description	Percent of Neutron Flux > 1 MeV	σ_{FE} (mb)
	Reference		
1	w=44.4 g/cm T= 57°C d= 0.985 g/cm ³ r _i = 1.988 cm BU= 0 MWD/TE	6.50%	106.6
	Insert Geometry Effect		
2	Vary Specimen Holder Size: w=33.2 g/cm	6.37%	107.7
3	Vary Specimen Holder Size: w=63.6 g/cm	6.69%	105.1
4	Vary Specimen Holder Position: r _i =0.794 cm	6.27%	104.4
5	Vary Specimen Holder Position: r _i =2.789 cm	7.41%	105.9
	Coolant Density Effect		
6	Vary water density: d= 0.50 g/cm ³	7.17%	104.3
7	Vary water density: d= 0.01 g/cm ³	8.08%	101.2
	Temperature Effect		
8	Vary Coolant Temperature: T = 300°C	6.66%	105.4
	Burnup Effect		
9	Vary Burnup: BU = 5000 MWD/TE (~100 days @ 1.05 MW/m)	6.63%	106.7

Notation:

- w = weight of specimen holder per unit length
- r_i = inner radius of the specimen holder annulus
- d = density of coolant
- T = temperature of coolant
- BU = burnup

Figure 1. A Typical NRU Mk4 FN Rod Assembly

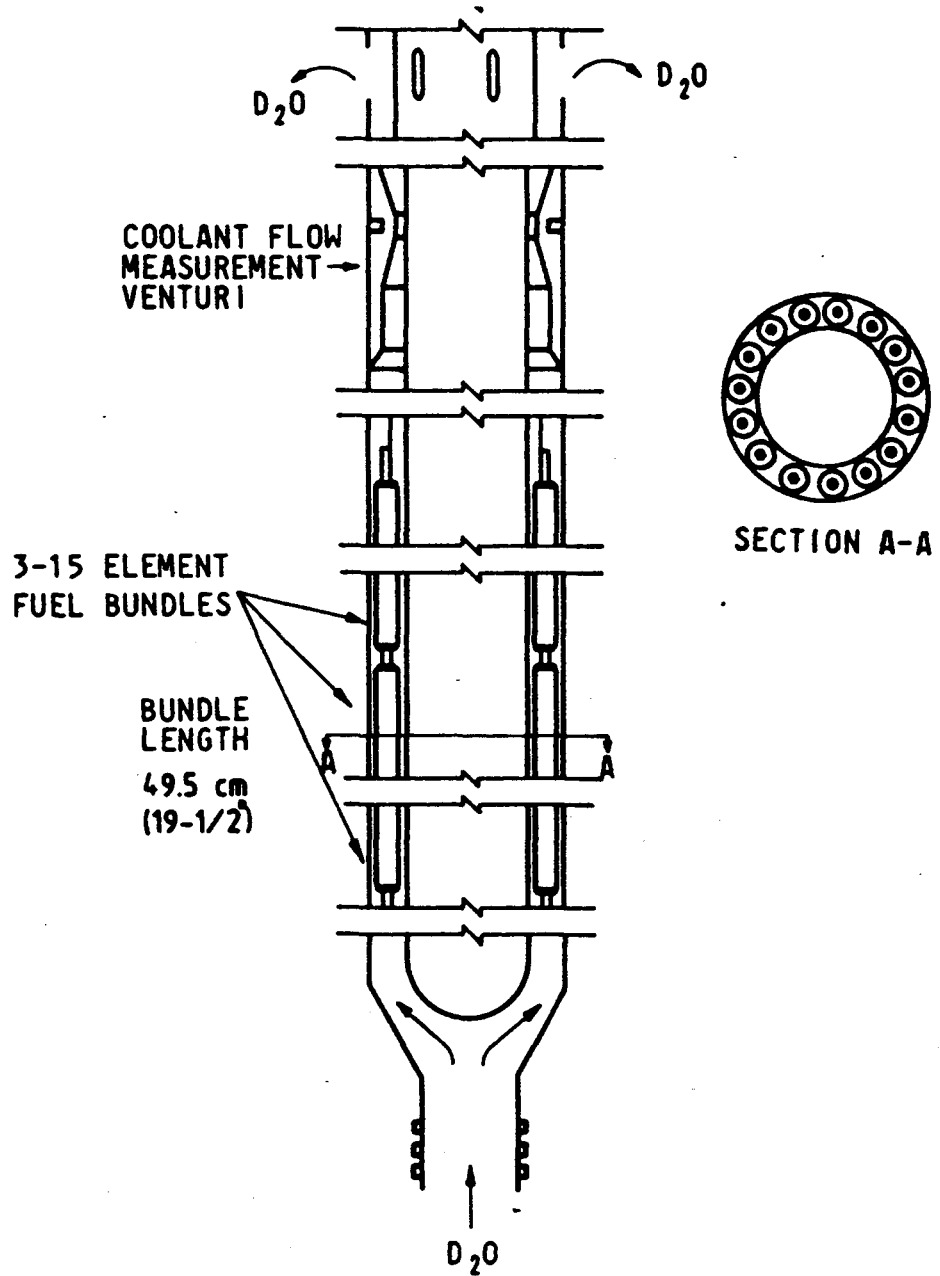

Figure 2. Sketch of the Super-cell Model Used for the NRU Mk4 FN Rod

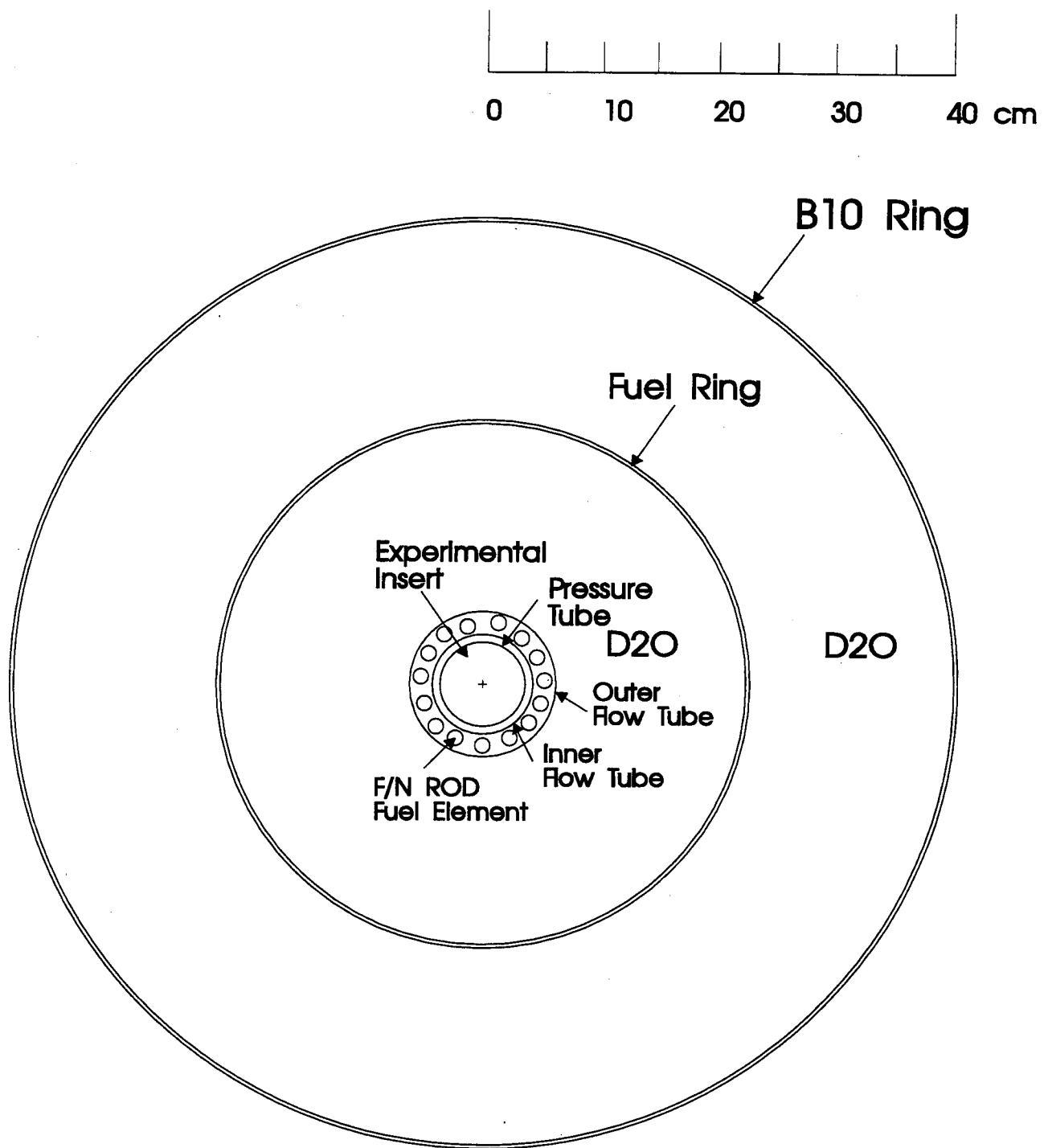

Figure 3. Sketch of the Model Used for a Typical Experimental Insert

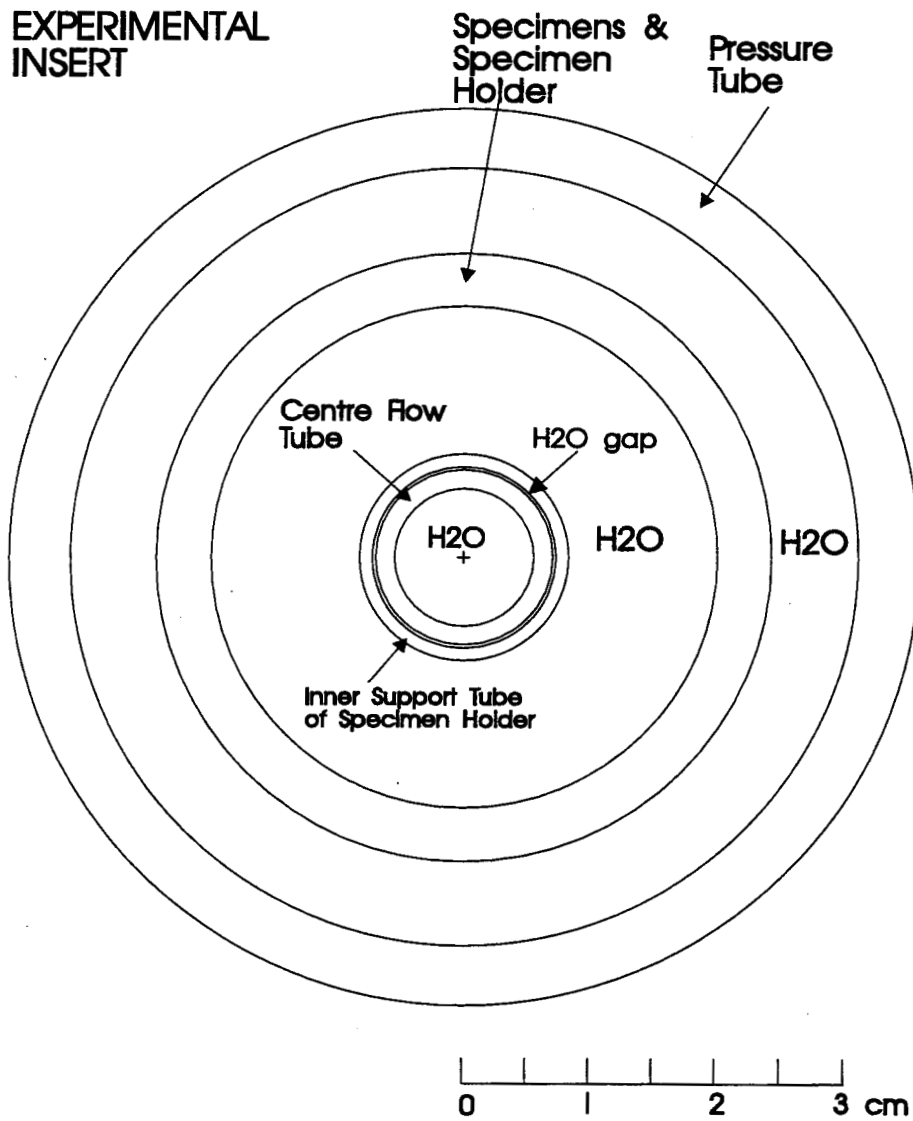

Figure 4. Comparison of Neutron Spectra In the NRU Mk4 FN Rod Cavity and In the Pressure and Calandria Tubes of a CANDU Fuel Channel Containing a 37-Element Bundle

